

Incidental Findings in Male Breast Carcinoma: A Genetic Counseling Approach

Manjima Chatterjee^{1,4}, M. L. Sheela¹, Upasana Mukherjee^{1,4}, Shekar Patil², C. T. Satheesh²,
Krithika Murugan², Radheshyam Naik², Nalini Rao², B. Mahesh², U. Ashraf Mannan³,
Vaijayanti Gupta³, Satish Sankaran³, B. S. Ajaikumar² and Mithua Ghosh^{1*}

¹*Triesta Sciences, HCG, Bangalore, Karnataka, India*

²*Health Care Global Enterprises Limited, Bangalore 560 027, Karnataka, India*

³*Strand Centre for Genomics and Personalized Medicine, Bangalore 560 024, Karnataka, India*

⁴*School of Bio Sciences and Technology, VIT University, Vellore 632 014, Tamil Nadu, India*

**E-mail: mithuaghosh@hcgoncology.com*

KEYWORDS Cancer. Diagnosis Challenges. Next Generation Sequencing. Personalized Therapy

ABSTRACT Male breast carcinoma (MBC) is a rare cancer type that accounts 1 percent of the total breast cancer cases. This substantially invites diagnosis challenges and social burdens where the individual needs more personalized therapies and genetic counseling to cope with the condition. This study aims to analyse a total of four male breast cancer cases with or without secondary recurrence. Tissue or saliva samples were analysed with informed and written consent for each individual subjecting to next generation sequencing aiming high throughput investigations. The results revealed two cancer syndromes in an individual with breast and thyroid carcinoma and mutations in PI3KCA, PTEN, NBN, RB1 genes. The rest three cases were identified with alterations in NBN, BRIP1 and BRCA2 mutations. Genetic counseling was provided to each participant and the responses were noted upon post-test targeted therapies.

INTRODUCTION

Cancer of the breasts is the most challenging targets in the decade of molecular therapeutics with its great morbidity and mortality worldwide. The meshwork of cell signalling and molecular pathways, mutational swifts and rapid change in the protein products has made targeting breast cancer a real issue. Out of the types of breast malignancies, cancers of the male breast is known to be a rare phenomenon that accounts about 1 percent of total breast cancers with an uneven global prevalence (Shah et al. 2009). Although no recent population studies have been reported, the actual incidence of male breast cancer (MBC) is undefined till date. In case of men, the onset and the causes of the disease can be similar to that of women where the only difference is, in males the condition is diagnosed in a later phase of life and thus the severity increases.

The age of onset for breast carcinoma is before 40 years in females and varies till 70 years of age, whereas in males the disease incidence is high at the age of 60-70 years (Mukherjee et al. 2014). There are both sporadic and genetic counterparts of breast cancer. Sporadic mutations are accidental and can trigger tumorigenesis at any time of life. On the other hand, germline mutations are hereditary that can be inherited from parents and passed on to the next generation. Sporadic mutations often arise from environmental exposures like ionizing radiations, occupational exposures, toxic chemicals, tobacco smoke, asbestos and viral infections irrespective of the gender (Boffetta and Nyberg 2003; Coyle 2004). Genetic factors support spectra of genes that could alone be mutated in breast cancers or altered with other associated genes. This mostly triggers tumorigenesis unless the mutation is silent. The panel of genes commonly reported in male breast cancer patients are BRCA2, Checkpoint kinase2 or CHEK2, PI3KCA, TP53, Partner, BRIP1, AKT1 and localizer of BRCA2 (PALB2), NBN and BRCA1 in few cases (Varon et al. 1999; Frank et al. 2007; Silvestri et al. 2011; Chrzanowska et al. 2012; Orloff et al. 2013; Mukherjee et al. 2014). Studies on BRCA1 mutation and male breast cancers have shown less to

Address for correspondence:

Dr. Mithua Ghosh, Ph.D.
Triesta Sciences (A Division of HCG)
HCG Towers, #8, P. Kalinga Rao Road,
Sampangi Ram Nagar,
Bangalore 560 027, Karnataka, India
Phone: +91 99807 57596
Fax: +91 80 2248 5962
E-mail: mithuaghosh@hcgoncology.com

no significant association (Giordano 2005; Chikaraddi et al. 2012; Rizzolo et al. 2013). Another key regulator in male breast cancer is estrogen and progesterone receptor hormones. Studies have documented estrogen positive (ER+) breast cancers to be higher than estrogen negative (ER-) (Rizzolo et al. 2013). This could be due to the radical effect of estrogen on male breast tissue that is able to facilitate the formation of acini and true lobules similar to that of observed in females. Study by Silvestri et al. (2016) reported pathogenic variation between male and female breast cancer, with higher ER+ and PR+ male breast cancer cases. Additionally, a high risk of BRCA2 mutation was also found in the study while compared to BRCA1 mutation in MBC and with female breast cancers. Earlier reports have shown men breast tumors receiving estrogen therapy for prostate cancers that proves the secondary involvement of an estrogen altered breast as a part of the metastatic malignancy (Shah et al. 2009). Involvement of HER2 in male breast cancers have also been reported, where HER2 positive (HER2 +) cancer cells are good molecular targets for drugs like trastuzumab (Herceptin) and Lapatinib (Tykerb®) (Ottini et al. 2010). Diagnosing male breast cancer at an early stage has become possible through identifying mutations in genes associated with breast and ovarian or prostate cancers with a single panel test. The difficulty of a number of genes involved in breast cancers and finding mutations in a single gene is resolved by testing the personalized gene panel through next generation sequencing. In case of male breast carcinoma, this multi gene testing has opened more accurate treatment options with targeted drug therapies and personalized medicines (Byers et al. 2016; Mannan et al. 2016).

Exploring the psychological issues of male breast cancers, India involves ethical and social concerns related to this. Male breast carcinoma being less common than female incorporates a feel of grief and shy that restricts its early detection and targets. Study by Brain et al. (2006) has reported psychological distress associated with male breast cancer analysis various aspects. Mental stress due to uncertainty and anxiety has been found in literatures. This could be because of unawareness, lack of information and guidelines for male breast cancers till date (Kipling et al. 2014). The reason for anxiety could come from the fear of social stigma, family af-

fairs, third party interference and genetic discriminations. Genetic counseling could act as an efficient tool to resolve conflicts, ethical dilemmas and protect the affected individuals or families from social disgrace.

Objectives

- To analyse cases of male breast cancers with the help of molecular diagnostics.
- To provide the probands and families with appropriate genetic counseling.

METHODOLOGY

Four cases of male breast cancers were analyzed. Somatic and germline mutation tests were done for the patients with informed and written consent. A pre-test counseling session was designed for each individual including detailed medical history of the patient, followed by analyzing pedigree based on data adequacy, explaining the importance of genetic testing, its benefits and risks as well as obtaining informed and written consent if the patients will for genetic tests. The counseling session was carried out in a nondirective and beneficial way to the patient maintaining all the rudimentary confidentiality in account. The somatic or germline or both the tests were suggested for patients depending on their cancer type or at risk family status. The Somatic mutation test was planned to detect somatic alterations in hot spot regions of 48 genes responsible for 18 solid tumors all over the body and interpret those with possible therapeutic, clinical or prognostic implications. The Germline mutation test was designed to cover either all the 86 important genes (including 23 hereditary cancer risk genes recommended by American College of Medical Genetics and Genomics, ACMG) associated with hereditary cancer predisposition, or to test genes related to single cancer type. Somatic mutation test (48 gene panel) was carried out by isolating genomic DNA from paraffin embedded FFPE blocks after the patients had undergone surgery or if any other biopsies were taken. The tissue was histopathologically checked for the confirmation of malignancy followed by Hematoxylin and Eosin staining (H&E staining) to check the tumor burden. A further Immunohistochemistry assay was done to identify the expressed markers to know the hormonal status for certain can-

cer types (example, ER, PR and Her2/Neu for breast cancer patients) and to determine the cancer subtypes like adenocarcinoma or squamous cell carcinoma. After all the pathological tests, the tissue was scrapped for genomic studies by taking two to three sections of 20microns. DNA was isolated from the tissue using Qiagen DNA-RNA FFPE Kit and the yield was quantified by Spectrophotometer (Nanodrop) followed by Qubit-fluorometric quantification. The samples were further subjected for Gene profiling test done by Next Generation Sequencing (NGS) using a standard v2 kit on Illumina Miseq platform. The genomic DNA was qualified using Illumina infinium assay and amplicon based library was constructed using the DNA samples. Libraries were pooled and loaded on Illumina Miseq platform to yield multitude of reads for region of interests. Analysis was done using Avadis NGS 1.6 and result was interpreted by bioinformatics tools. On the other side, the germline mutation analysis test was done from the patient's saliva sample (0.5 ml) using Oragene saliva collection kit on an informed and written consent. The samples were inactivated at 50°C for 8 hours using water bath and the DNA was isolated using Prep IT-L2P kit (DNA Genotek, Canada). The samples were then used for preparing the "DNA sequencing-ready" library. The DNA was quantified using Qubit Fluorometer taking 50ng sample for library preparation. "Nextera" library was constructed using a transposon based shearing of the genomic DNA. By this protocol, "tagmented" (fragmented and tagged simultaneously in the same tube) DNA was constructed prior to sequencing. Incorporation of adaptors, platform-specific tags and barcodes were obtained by limited cycle PCR step to prepare DNA sequencing libraries. Quality and quantity were measured for all the tagged and amplified sample libraries, followed by sequencing using a standard v2 kit on Illumina Miseq with the expected data output of 4-5 GB. The variant detection algorithm in Strand NGS v2.1.6 was used to detect variants in the target regions. The data were uploaded into StrandOmics v3.0 (<https://alpha.strandomics.com/>) a proprietary clinical genomics interpretation and reporting platform from Strand Life Sciences) for all subsequent analysis and variant interpretations. The post-test counseling session was arranged for the patients and their families on receiving the genomics test results. With all the confidentiality, the results

were disclosed to the patients and risk for first, second or third degree relatives were also discussed based on the underlined genetic results. The patient families were given information about the management of the disease and a further gene profiling was suggested for family members at risk. The patients were given moral support to cope with their conditions and best management guidelines were provided for early detection and prevention with medical excellence, personalized therapies and further person centered genetic and psychological counseling.

Case Presentations

Report 1: A 46 years male was reported with a known case of carcinoma of the right breast with significant pain in the chest. He had undergone eight cycles of chemotherapy and was on Tamoxifen. The patient had a history of diabetes and hypertension and not a known case of asthma. A second diagnosis was metastatic thyroid carcinoma with spondylotic changes of the thoracic spine canal or neural foraminal stenosis. MRI of the thoracic spine unveiled a well-defined hyperintensity at the lateral margin of the 5th rib of concern for metastasis. Proband was counseled for genomic testing as a further presence of renal cell carcinoma was reported in his sister. Detailed medical history was taken for the patient and both the actionable and germline mutation analysis were suggested for him. He was counseled for genetic testing and 13 genes (ATM, BRCA1, BRCA2, BRIP1, CDH1, CHEK2, NBN, PALB2, PTEN, RAD51C, RAD51D, STK11, TP53) associated with hereditary breast cancer was checked with informed and written consent. Other 23 genes recommended by American College of Medical Genetics and Genomics (ACMG) were investigated for either key or incidental findings.

Report 2: An 80 years old male was reported with a known case of male breast carcinoma (left) and had no family history of any cancer type. Due to psychological distress, the patient was counseled with care and suggested for somatic and germline mutation tests. With informed and written consent 48 genes were screened having mutation hot spots and those have targetable drugs with possible therapeutic, clinical or prognostic implications. Germline test analysed a total number of 13 genes associated with hereditary breast cancer similar to case 1 with additional 23 genes recommended by American Col-

lege of Medical Genetics and Genomics (ACMG) for key or incidental findings.

Report 3: Another classical case of male breast cancer was presented of a 45 years male diagnosed with carcinoma of the right breast. No known family history of cancer types were noted during counseling. He was suggested for genetic testing covering the 13 hereditary breast cancer associated genes and 23 genes recommended by American College of Medical Genetics and Genomics (ACMG).

Report 4: A 74 years male was presented with a known case of bilateral male breast cancer. He had undergone lumpectomy in the both breasts and was reported as a triple negative (TNBC) for ER, PR and Her2/Neu hormone receptors. An existing family history of stomach, breast and bone cancer was also noted during the counseling session (Fig. 1). The patient was counseled for genetic testing to know the presence of any germline mutation and saliva was collected on informed and written consent. Both the 13 genes for hereditary breast cancer and 23 genes American College of Medical Genetics and Genomics (ACMG) recommended genes were analysed.

RESULTS

Detailed analysis and follow up of four male breast cancer cases rendered us with three different syndromes having underlined genetic alterations.

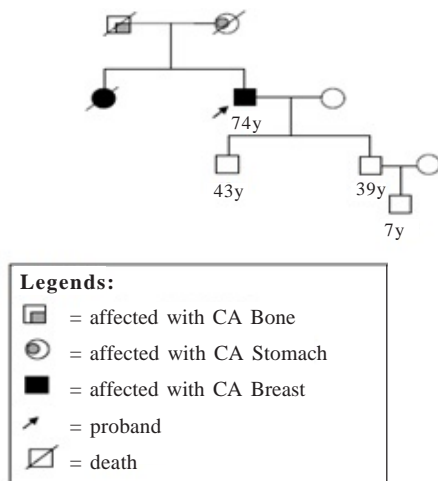

Fig. 1. Family history of stomach, breast and bone cancer

Somatic or actionable gene profiling for case 1 had come up with mutated PTEN and PI3KCA genes from the tissue of thyroid gland. An additional germline mutation was noted in the NBN gene with an evidence of breast cancer predisposition. The PI3KCA variation was identified in chromosome 3, exon 21 with an alteration of Histidine to Arginine amino acid. The second alteration was noted as a novel missense mutation in PTEN gene present on chromosome 10q 23.3, exon 6 with a change in Threonine to Isoleucine amino acid sequence. Additionally, alteration in exon 17 of RB1 gene was noted to cause change in amino acid Arginine to Leucine (p.Arg552Leu) with no known actionable therapy. The germline mutation was investigated for a total number of 24 genes associated with hereditary breast and endocrine cancer predisposition as well as 23 genes recommended by American College of Medical Genetics and Genomics (ACMG) which showed a heterozygous variation in the 10th exon of NBN gene present on chromosome 8 resulting alteration in the amino acid from Threonine to Isoleucine. The identified missense substitution p.Thr434Ile alters a conserved residue in the protein and the variant was found to be novel as no reports have been documented till date in the literature.

Case 2 had come up with a heterozygous NBN gene mutation in chromosome 8, exon 2 with an identified variant predicted to cause a missense substitution at codon 35 and a replacement in Isoleucine residue by amino acid valine.

In case 3, analysis of the 23 genes recommended by ACMG showed a heterozygous variant of unknown significance (VUS) in the 10th exon of BRIP1 gene present on chromosome 17. The identified missense substitution p.His478 Arg was reported to alter a conserved residue to protein.

Case 4 was identified with a heterozygous germline mutation in BRCA2 gene present on chromosome 13 with a pathogenic clinical significance and specified a deletion responsible in causing a frameshift mutation that leads to premature termination of the protein. The truncated protein had been reported to lack major functional domains of BRCA2, such as the BRC1 to BRC8 repeat motifs, the DNA binding domain and the nuclear localization signal (NLS) motifs that would be responsible for loss-of-function. Additional somatic mutations were found in RB1

and PTEN genes. RB1 genes showed two alterations in chromosome 13, G>T resulting in p.Val157Leu and C>T resulting in p.Ser707Phe changes in amino acids. PTEN mutation was seen in chromosome 10 that resulted in codon termination from a lysine residue (p.Lys221Ter).

DISCUSSION

The genetic analysis of four male breast cancer cases enriched the discussion by presenting different molecular findings and two cancer syndromes running in a single individual. Although the final impression was difficult indeed, consolidating the genetic data and establishing a phenotype genotype correlation helped us in determining the diagnosis and present it as a rare case. In case 1, the clinical interventions along with genetic evidences met the criteria of Cowden Syndrome, a rare cancer type found among patients affected with both breast and thyroid carcinoma at the same time (Kim 2016; Yakubov et al. 2016). PTEN mutation added the value to the interpretation, following an additional PI3KCA gene alteration that suits the criteria of the syndrome as the whole PI3K-AKT pathway is deconstructed in such patients. The second major criterion was fulfilled as the sister of the proband had succumbed due to the presence of renal cell carcinoma (RCC) of both the kidneys. Moreover, studies with relatively similar clinical and genetic findings strengthened the present observation of Cowden syndrome (Amani and Miraoui 2016; Pistorius et al. 2016).

The novel variation in NBN gene with supportive clinical data met the criteria of another rare cancer syndrome. Recurrent Sino pulmonary infection, early death of a sibling, history of reproductive challenges fulfilled the criteria of representing Nijmegen Breakage Syndrome in the individual. Cowden syndrome is a subtype of multiple hamartoma syndromes, characterized by the development of multiple hamartomas in any organ, as well as an increased risk for carcinoma (Allain 2008). It is an autosomal dominant syndrome associated with an increased risk of developing several types of cancer, specifically cancers of the breast, thyroid and the lining of the uterus known as the endometrium. Males with Cowden syndrome have been previously reported with breast cancer as well as an occurrence of thyroid cancer; they especially have a lifetime risk of developing non medullary

thyroid carcinoma if not predisposed earlier in lifetime. Additionally, renal cell carcinoma has also been reported as the diagnostic criteria for Cowden syndrome. The global incidence of Cowden Syndrome is 1 in 200,000 making the syndrome such a rare and challenging one to diagnose, treat and manage. There have been certain criteria proposed by International Cowden Consortium firstly in 1995 that helps identifying patients with such syndrome. The individual with Cowden Syndrome must meet at least two of major criteria with one relative predisposed to any major or minor criteria accepted globally (Eng 2000). An additional confirmation was the presence of germline mutation in the PTEN gene, followed by a further mutation in either PI3K or AKT downstream genes (Orloff et al. 2013). A yearly thyroid or dermatologic evaluation is needed for both paediatric and adult cases as well as breast screening such as mammogram or an MRI is helpful (Eng 2001). Genetic counseling is beneficent for patients with Cowden syndrome as they have a risk of passing the present mutation to their offspring. Cowden being an autosomal dominant syndrome bares a 50 percent chance of getting expressed even in the siblings of the affected individual or proband. Thus counseling helps the family members to understand the risk of disease predisposition to associated cancer types as well as provide the needful information for regular screening and management of the disease. Genetic counseling is effective indeed for cases like Cowden syndrome with a predisposition to both breast and thyroid cancer in one individual. It provides management options with early screening diagnosis at the right time. Children with such family history may undergo an annual thyroid examination after reaching the age of 18 years. Adult must follow an annual thyroid ultrasound with dermatological evaluation, breast examination (NCCN Breast examination guidelines) as well as colonoscopy as a routine screening procedure (Eng 2001). Genetic counselors provide the family members with flawless information regarding the clinical condition, risk of first, second and third degree relatives, importance of genetic testing for mutation identification and for early management and disease prevention.

Nijmegen Breakage Syndrome (NBS) is an autosomal recessive syndrome bearing the clinical symptoms like microcephaly, growth retardation, combined immunodeficiency and pre-

disposition to malignancies (Chrzanowska et al. 2012). NBS is considered to be rare syndrome as the global incidence being 1 in 100,000 individuals. Patients with such syndrome may acquire congenital renal anomalies, hypospadias, cryptorchidism, urethroanal fistula as well as immune deficiency with life threatening recurrent respiratory and a strong predisposition to malignancies and identified radio sensitivity. Patients affected with NBS have also been presented with thyroid carcinoma, Ewing sarcoma as well as glioma, meningioma, neuroblastoma and gonadoblastoma in their lifetime with a history of a sibling with any malignancies followed by an early death (Chrzanowska et al. 2012). NBS can be predisposed as the result of mutations in NBN gene present on chromosome 8q21q24 that lead to functional truncated fragments of nibrin protein, involved in repairing DNA double strand breaks (Salewsky et al. 2016). Genetic counseling is required in case of families having individual affected with Nijmegen breakage Syndrome as being an autosomal recessive syndrome there is always a 25 percent chance of the offspring being affected by the syndrome. The parents of the affected child are the obligate carriers of the NBN mutation and the siblings of the proband's parents have a 50 percent chance of being affected by such syndrome. Interestingly, the heterozygous carriers of NBN gene mutation do not express any symptoms, though in some populations based studies the association between heterozygous carriers and increased cancer risk was investigated for the carriers with founder mutation c.657_661del5 (Chrzanowska et al. 2012). Thus, this syndrome needs special medical excellence for relevant management and healthy survival. Continuous monitoring, early detection is needed and genetic counseling plays an important role in guiding the affected individuals or families. A carrier testing for at-risk family members and prenatal testing can be recommended in case both of the pathogenic variants have been identified in an affected family member (Varon et al. 1999). Literature studies have revealed a poor correlation between heterozygous carriers of NBN mutation with its clinical symptoms. Parents of the proband being obligate carriers, may also be offered screening for cancer predictive testing (Chrzanowska et al. 2012). Intravenous immunoglobulin g (IVIg) treatment is considered in individuals with various humoral immunodeficiency and periodic infections. A frequent follow up helps monitoring

the mental and physical growth of affected individuals and the frequency of recurrent infections in them. A screening must be recommended for premature ovarian insufficiency in females. In case of patients with NBS, radiotherapy is usually avoided as the cells are more prone to be radiosensitive that might assist several other medical complications (Varon et al. 1999).

Other three cases were also counseled as per the standard criteria. Screening for male breast cancers are established based on that of developed for the women. Genetic counseling is helpful for male patients with breast cancers as lot of psychological implications have been found associated with it. On assessment of the family history, the risk of expressing the disease can be perceived and guidelines can be provided for self-breast examination as same for women as per the NCCN guidelines 2015, version 2.2015. At-risk individuals can be counseled for an annual breast examination with an ultrasound, MRI or for a routine blood components study for detecting any physical and biochemical changes in concern. Genetic testing is worthwhile as a screening option for MBCs with or without family history, as a vast range of susceptible genes has been identified kindred disease prevalence. Mutation analysis of genes such as BRCA1, BRCA2, BRIP1, PALB2, ATM, CDH1, CHEK2, NBN, PTEN, RAD51, TP53 and many others have been detected to be altered in male breast cancers with variable penetrance and expressivity. Genetic counseling may help identifying the low, moderate and high penetrate genes, mutations in them and the risk of individuals being affected due to this. MBC requires a personalized and extensive approach towards its diagnosis and treatment, in which the knowledge of risk factors, family history, genetic susceptibility and predisposition bear a major role. Recent studies highlighted the importance of educational programs in regards to patient's awareness irrespective of gender and ages about the clinical condition, as well as significant availability of preoperative and postoperative gender-specific information to palliate psychological stigma associated with breast cancer diagnosis (France et al. 2000; Rizzolo1 et al. 2013).

CONCLUSION

This study presents a total of four male breast cancer cases, out of which one individual

was found to be affected with two distinct cancer syndromes. The rest of the cases were identified with male breast cancers having different mutation profiles. Genetic counseling was provided to the family members with flawless knowledge about the disease condition, surveillance, genetic testing availability and implications along with management. The incidences of syndromes identified were found to be less in global data and thus presented as rare cancer types as per the world cancer registries. Pedigree analysis, risk assessment, disclosure of the genetic test results were done under strict confidentiality. Decision was made by the medical board with the help of genetic counselors for further personalized treatment in case the affected individuals had come up with certain somatic mutations that have FDA approved targeted drugs. Patients with detected germline gene mutations were counseled considering factors like age, gender, hormonal status, past medical history and family history for risks of the relatives, especially the siblings or offsprings of inheriting the same faulty allele. Case 1 with PI3KCA and PTEN somatic mutations was found to be a good responder of m-TOR inhibitor therapies, Everolimus and aromatase inhibitors, as well as a poor responder of Trastuzumab based on the research evidences that mutations in PI3KCA contribute to lack response to HER2 targeting agents in HER2 positive breast cancer patients. Mutations in PTEN gene indicated a moderate response to Everolimus and a poor response to anti-HER2 therapy as previous studies revealed that metastatic breast carcinoma patients with PI3K pathway activating mutations, including PTEN loss were found to be less sensitive to Trastuzumab and Lapatinib. Variants in PTEN found in case 4 showed a possible response to Everolimus and a poor response to Trastuzumab. Thus personalized therapies are helping patients providing the right treatment at the right time based on their genetic profiles, reducing the risk of disease recurrence. In conclusion, medical excellence with the support of genetic counseling and personalized medicines is driving the fate of cancers towards a manageable condition.

REFERENCES

- Allain DC 2008. Genetic counseling and testing for common hereditary breast cancer syndromes: A paper from the 2007 William Beaumont hospital symposium on molecular pathology. *The Journal of Molecular Diagnostics*, 10(5): 383-395.
- Amani MEA, Miraoui 2016. The Cowden syndrome: A case report. *International Journal of Clinical Case Reports*, 6(12): 1-3.
- Boffetta P, Nyberg F 2003. Contribution of environmental factors to cancer risk. *British Medical Bulletin*, 68(1): 71-94.
- Brain K, Williams B, Iredale R, France L, Gray J 2006. Psychological distress in men with breast cancer. *Journal of Clinical Oncology*, 24(1): 95-101.
- Byers H, Wallis Y, van Veen EM, Lalloo F, Reay K 2016. Sensitivity of BRCA1/2 testing in high-risk breast/ovarian/male breast cancer families: Little contribution of comprehensive RNA/NGS panel testing. *European Journal of Human Genetics*, 57: 1-7.
- Chikaraddi SB, Krishnappa R, Deshmane V 2012. Male breast cancer in Indian patients: Is it the same? *Indian Journal of Cancer*, 49(3): 272.
- Chrzanowska KH, Gregorek H, Dembowska-Bagińska B, Kalina MA, Digweed M 2012. Nijmegen breakage syndrome (NBS). *Orphanet Journal of Rare Diseases*, 7(1): 1.
- Coyle YM 2004. The effect of environment on breast cancer risk. *Breast Cancer Research and Treatment*, 84(3): 273-288.
- Domchek SM 2014. Evolution of genetic testing for inherited susceptibility to breast cancer. *Journal of Clinical Oncology*, 32: 1-2
- Eng C 2000. Will the real Cowden syndrome please stand up: Revised diagnostic criteria. *Journal of Medical Genetics*, 37(11): 828-830.
- Eng C 2001. PTEN Hamartoma Tumor Syndrome. In: RA Pagon, MP Adam, HH Ardinger (Eds.): *GeneReviews® [Internet]*. Seattle, WA: University of Washington, Seattle, 1993-2016.
- Ferrari N, Mohammed ZM, Nixon C, Mason SM, Mallon E 2014. Expression of RUNX1 correlates with poor patient prognosis in triple negative breast cancer. *PLoS One*, 9(6): e100759.
- France L, Michie S, Barrett-Lee P, Brain K, Harper P 2000. Male cancer: A qualitative study of male breast cancer. *The Breast*, 9(6): 343-348.
- Frank B, Hemminki K, Meindl A, Wappenschmidt B, Sutter C 2007. BRIP1 (BACH1) variants and familial breast cancer risk: A case-control study. *BMC Cancer*, 7(1): 1.
- Giordano SH 2005. A review of the diagnosis and management of male breast cancer. *The Oncologist*, 10(7): 471-479.
- Kim M 2016. Predisposing gene associated with Cowden syndrome discovered, with high thyroid cancer risk. *Oncology Times*, 38(1): 33-34.
- Kipling M, Ralph JE, Callanan K 2014. Psychological impact of male breast disorders: Literature review and survey results. *Breast Care*, 9(1): 29-33.
- Mannan AU, Singh J, Lakshmikeshava R, Thota N, Singh S 2016. Detection of high frequency of mutations in a breast and/or ovarian cancer cohort: Implications of embracing a multi-gene panel in molecular diagnosis in India. *Journal of Human Genetics*, 61: 515-522.
- Mukherjee A, Saha A, Chattopadhyay S, Sur PK 2014. Clinical trends and outcomes of male breast cancer: Experience of a tertiary oncology centre in

- India. *International Journal of Cancer Therapy and Oncology*, 2(3)
- Orloff MS, He X, Peterson C, Chen F, Chen JL 2013. Germline PIK3CA and AKT1 mutations in Cowden and Cowden-like syndromes. *The American Journal of Human Genetics*, 92(1): 76-80.
- Ottini L, Capalbo C, Rizzolo P, Silvestri V, Bronte G 2010. HER2-positive male breast cancer: an update. *Breast Cancer: Targets and Therapy*, 2: 45.
- Pistorius S, Klink B, Pablik J, Rump A, Aust D 2016. An unusual case of Cowden syndrome associated with ganglioneuromatous polyposis. *Hereditary Cancer in Clinical Practice*, 14(1): 11.
- Rizzolo P, Silvestri V, Tommasi S, Pinto R, Danza K 2013. Male breast cancer: Genetics, epigenetics, and ethical aspects. *Annals of Oncology*, 24(Suppl 8): viii75-viii82.
- Salewsky B, Hildebrand G, Rothe S, Parplys AC, Radziewski J 2016. Directed alternative splicing in Nijmegen Breakage Syndrome: Proof of principle concerning its therapeutical application. *Molecular Therapy*, 24(1): 117-124.
- Shah P, Robbani I, Shah O 2009. Clinicopathological study of male breast carcinoma: 24 years of experience. *Annals of Saudi Medicine*, 29(4): 288.
- Silvestri V, Rizzolo P, Falchetti M, Zanna I, Masala G 2011. Mutation analysis of BRIP1 in male breast cancer cases: A population-based study in Central Italy. *Breast Cancer Research and Treatment*, 126(2): 539-543.
- Silvestri V, Barrowdale D, Mulligan AM, Neuhausen SL 2016. Male breast cancer in BRCA1 and BRCA2 mutation carriers: Pathology data from the Consortium of Investigators of Modifiers of BRCA1/2. *Breast Cancer Research*, 18(1): 1.
- Varon R, Demuth I, Digweed M 1999. Nijmegen Breakage Syndrome. In: RA Pagon, MP Adam, HH Ardinger (Eds.): *GeneReviews® [Internet]*. Seattle, WA: University of Washington, Seattle, 1993-2016.
- Yakubov E, Ghoochani A, Buslei R, Buchfelder M, Eyüpoglu IY 2016. Hidden association of Cowden syndrome, PTEN mutation and meningioma frequency. *Oncoscience*, 3: 5-6.